



JOB NAME:	CONTRACTOR:
JOB LOCATION:	APPROVAL:
ENGINEER:	CONTRACTOR P.O.:
APPROVAL:	REPRESENTATIVE:

8E0227-00*

6600LL 2-WAY UNIBODY CARBON STEEL, FNPT THREADED SEAL WELDED BALL VALVE WITH VALBIA ELECTRIC ACTUATOR AND BRACKET

SIZES 1/4" TO 2"

*001	12V AC/DC	*002	24V AC/DC	*003	100-240V AC
01	BATTERY BACKUP	*02*	POSITIONER	*04*	BATTERY BACKUP W POSITIONER

SPECIFICATIONS

The 8E0227 series features the Bonomi 6600LL full port, seal-welded design, WCB steel body, 316 SS ball & stem, with 25% carbon reinforced TFE seats, graphite stem packing, and a drilled and tapped rear mounting pad. A thermal relief hole in the stem slot is standard. In addition, the 6600LL has a grounded ball and stem, is NACE MR 0175 compliant, and is fire-safe.

The Valbia VB series actuator housing is made from a high impact resistant techno polymer, and standardly features dual motors, two extra limit switches, a heater & thermostat, a torque limiter, dual ISO patterns, female star drive, position in-dicator, PG11 connections, and a 75% duty cycle motor. The actuator is also NEMA 4,4X rat-

ACTUATOR FEATURES

- NEMA 4, 4X Housing
- 12V/24V AC/DC and 100-240V AC Models Available
- ISO 5211 dual patterns
- VB015 -12/24V AC - 50% Duty Cycle
- VB030-VB110 - 12/24V DC and 100-240V AC - 75% Duty Cycle
- High-Strength, Impact Resistant IP67 Technopolymer Housing
- Temperature Range -4°F to 131°F
- PG11 Electrical Connection/Optional 1/2" Conduit

VALVE FEATURES

- Unibody WCB body
- Full port, sizes 1/4" to 2"
- Fire-safe Design
- Grounded ball and stem
- Self adjusting stem packing
- Blow out proof stem design
- 100% air tested under water at 80 psi
- Pressure rating 1/4" to 2" 2000 psi - 200 psi steam
- Temperature range -4°F to 450°F
- Mounting pad for actuator
- Thermal relief hole in stem slot

PRESSURE - TEMPERATURE CHART FOR SERIES 6600LL

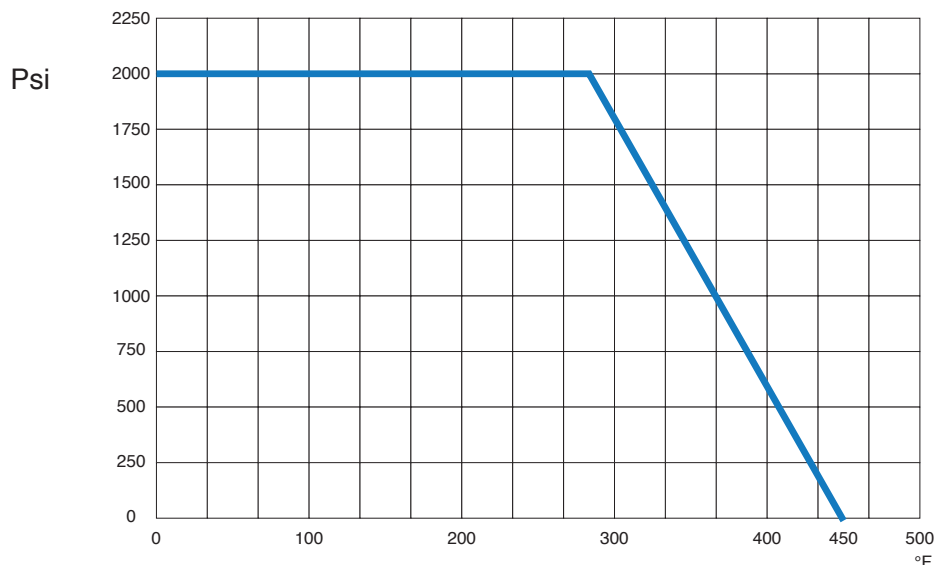

BILL OF MATERIALS FOR 6600LL

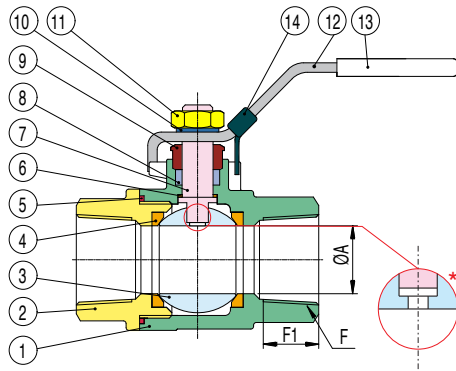

N POS	PART NAME	MATERIAL	N PCS
1	BODY	WCB	1
2	END CAP	WCB	1
3	BALL	AISI 316	1
4	SEAT	R.P.T.F.E.	2
5	JOIN GASKET	P.T.F.E.	2
6	THRUST WASHER	P.T.F.E.	1
7	STEM	AISI 316	1
8	V RING PACKING	P.T.F.E.	1
9	GLAND BUSH	STEEL	1
10	STEM WASHER	STEEL	1
11	STEM NUT	STEEL	1
12	HANDLE	STEEL	1
13	HANDLE SLEEVE	VINYL	1
14	LOCKING DEVICE	SS304	1

DIMENSIONS

Size	1/4"	3/8"	1/2"	3/4"	1"	1-1/4"	1-1/2"	2"
A	0.45	0.49	.059	0.78	0.98	1.25	1.49	1.96
B	11.38	11.38	12.26	12.59	13.91	16.15	16.84	18.69
C	9.03	9.03	9.43	9.58	11.18	14.47	12.78	14.20
D	4.84	4.84	4.84	4.84	6.18	6.18	6.18	7.28
E	6.41	6.41	6.41	6.41	7.50	7.50	7.50	8.43
F	1.96	1.96	2.36	2.51	2.79	3.07	3.38	3.74
Act.	VB015	VB015	VB015	VB015	VB030	VB030	VB030	VB060

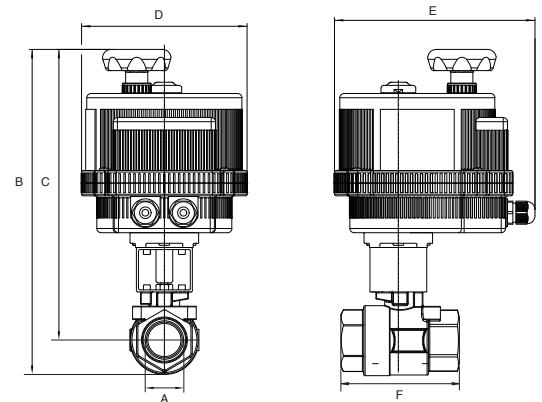

ON/OFF WIRING DIAGRAM - VB015

12V AC/DC, 24V AC/DC & 100-240VAC

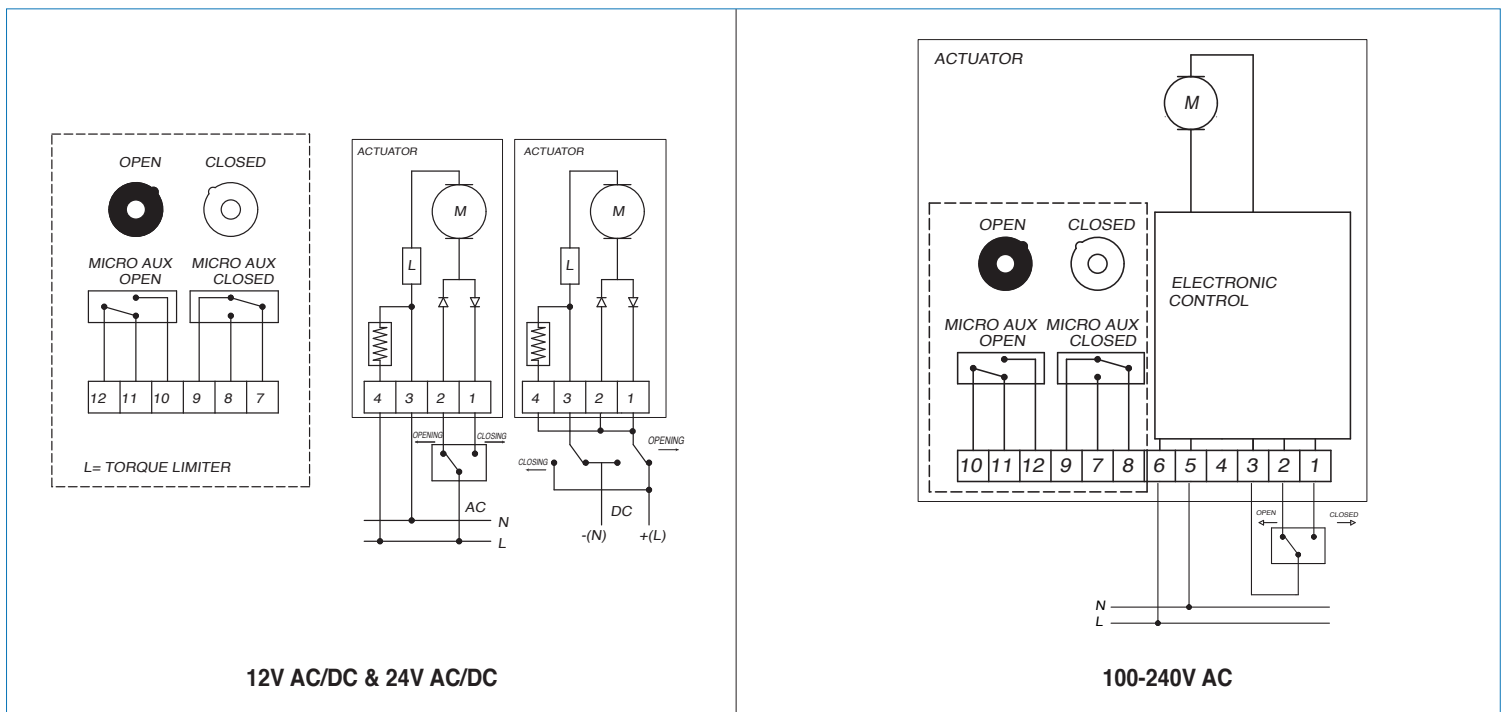

ON/OFF WIRING DIAGRAM - VB030 -VB060

12V AC/DC, 24V AC/DC & 100-240VAC

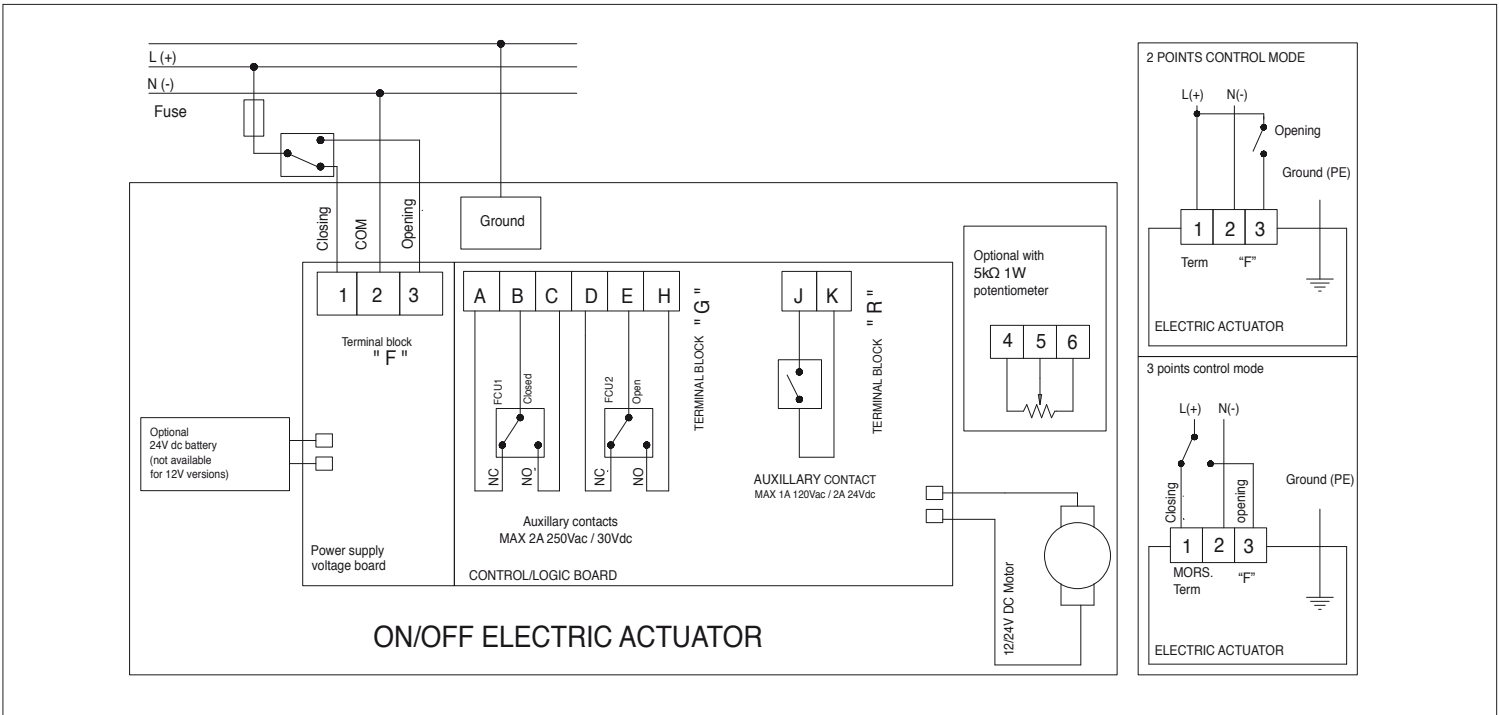

POSITIONER WIRING DIAGRAM - VB030 -VB060

12V AC/DC, 24V AC/DC & 100-240VAC

