

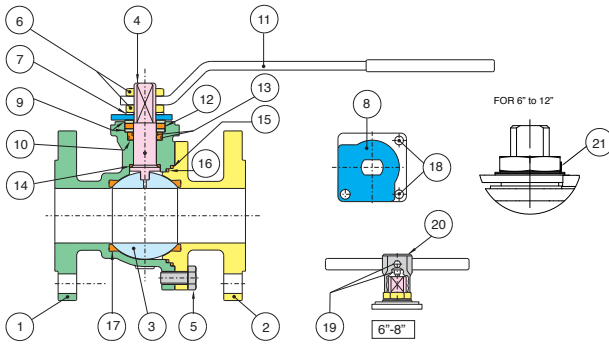

## BILL OF MATERIALS FOR 760021V36/V6/V9



N POS	PART NAME	MATERIAL	N PCS
1	BODY	A351 CF8M	1
2	END CONNECTION	A351 CF8M	1
3	BALL	A479-316/A351 CF8M	1
4	STEM	A276-316	1
5	SCREW	STEEL	4-8
6	NUT	STEEL	1-2
7	SPRING WASHER	STEEL	2
8	TRAVEL STOP	STEEL	1
9	PACKING GLAND	STEEL	2
10	STEM SEAL	P.T.F.E.	1
11	HANDLE	STEEL	1

N POS	PART NAME	MATERIAL	N PCS
12	STEM SEAL	GRAPHOIL	1
13	O-RING	FKM (Viton®)	2
14	THRUST WASHER	P.T.F.E.	1
15	SEAL	GRAPHOIL	1
16	SEAL	P.T.F.E.	1
17	BALL SEATS	R.P.T.F.E.	2
18	SCREW	STEEL	2
19	SCREW	STEEL	2
20	BODY HANDLE	CAST IRON	1
21	UNSCREWING GROWER	A182-F316	1

## DIMENSIONS

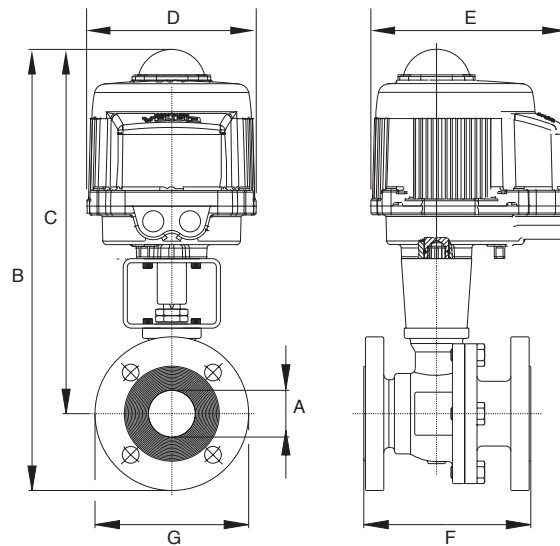

Size	1/2"	3/4"	1"	1-1/2"	2"	3"	4"	6"
<b>A</b>	.500	.750	.980	1.50	1.97	3.00	3.94	5.91
<b>B</b>	11.52	11.93	12.78	16.64	17.40	22.63	24.27	29.53
<b>C</b>	9.96	10.19	10.66	13.05	13.46	17.53	18.50	21.17
<b>D</b>	6.34	6.34	6.34	6.93	6.93	10.63	10.63	10.83
<b>E</b>	7.36	7.36	7.36	7.76	7.76	10.47	10.47	10.98
<b>F</b>	4.25	4.62	5.00	6.50	7.00	8.00	9.00	15.5
<b>G</b>	3.50	3.88	4.25	5.00	6.00	7.50	9.00	11.0
<b>Act.</b>	VB030M	VB030M	VB030M	VB060M	VB060M	VB110M	VB190M	VB350M

## CV VERSUS VALVE OPENING PERCENTAGE

Size	Degree	10%	20%	30%	40%	50%	60%	70%	80%	90%
1/2"	30-60°	0	0.0	0.1	0.2	0.4	0.6	1.0	1.7	3
	60°	0	0.1	0.2	0.4	0.7	1.2	1.9	3.3	6
	90°	0	0.1	0.3	0.7	1.2	2.0	3.4	5.9	10
3/4"	30-60°	0	0.1	0.2	0.5	0.8	1.3	2.2	3.9	6
	60°	0	0.1	0.4	0.9	1.5	2.6	4.3	7.5	12
	90°	0	0.3	0.8	1.6	2.7	4.6	7.7	13.3	22
1"	30-60°	0	0.1	0.4	0.8	1.4	2.4	4.0	6.9	11
	60°	0	0.3	0.8	1.6	2.7	4.6	7.7	13.4	22
	90°	0	0.5	1.4	2.8	4.9	8.2	13.7	23.7	39
1-1/4"	30-60°	0	0.2	0.7	1.3	2.3	3.9	6.5	11.3	18
	60°	0	0.4	1.3	2.5	4.5	7.6	12.7	21.9	36
	90°	0	0.8	2.2	4.5	8.0	13.4	22.4	38.8	64
1-1/2"	30-60°	0	0.3	1.0	2.0	3.5	5.9	9.8	17.0	28
	60°	0	0.7	2.0	4.0	7.1	11.9	20.0	34.5	57
	90°	0	1.1	3.3	6.6	11.6	19.5	32.6	56.4	93
2"	30-60°	0	0.5	1.5	3.1	5.5	9.2	15.4	26.7	44
	60°	0	1.1	3.1	6.3	11.1	18.7	31.2	54.0	89
	90°	0	2.0	6.0	12.0	21.2	35.6	59.5	102.9	170
3"	30-60°	0	1.3	3.9	7.8	13.8	23.2	38.9	67.2	111
	60°	0	2.7	7.9	16.0	28.2	47.4	79.3	137.1	227
	90°	0	4.7	13.6	27.3	48.1	80.9	135.4	234.1	387
4"	30-60°	0	2.1	6.1	12.3	21.6	36.3	60.8	105.2	174
	60°	0	4.3	12.4	25.0	44.1	74.1	124.1	214.5	355
	90°	0	8.1	23.6	47.5	88.8	140.8	235.7	407.50	675
6"	30-60°	0	4.7	13.7	27.6	48.7	81.9	137.0	236.9	392.0
	60°	0	9.6	28.0	56.3	99.3	166.8	279.3	482.8	799.0
	90°	0	17.7	51.6	103.8	183.1	307.6	514.9	890.2	1473.0

## POSITIONER WIRING DIAGRAM - VB030M -VB350M

12V AC/DC, 24V AC/DC & 100-240VAC

