



JOB NAME:	CONTRACTOR:
JOB LOCATION:	APPROVAL:
ENGINEER:	CONTRACTOR P.O.:
APPROVAL:	REPRESENTATIVE:

MEN500N

RUBBER-LINED DIRECT MOUNT, WAFER STYLE BUTTERFLY VALVE WITH EPDM SEATS AND NYLON DISC WITH VALBIA METAL ELECTRIC ACTUATOR
SIZES 2" TO 12"

ME530N - VITON SEATS

MEN500S

RUBBER-LINED DIRECT MOUNT, WAFER STYLE BUTTERFLY VALVE WITH EPDM SEATS AND STAINLESS STEEL DISC WITH VALBIA METAL ELECTRIC ACTUATOR
SIZES 1-1/2" TO 12"

ME530S - VITON SEATS

ME540S - BUNA SEATS

*001 12V AC/DC	*002 24V AC/DC	*003 100-240V AC
01 BATTERY BACKUP	*02* POSITIONER	*04* BATTERY BACKUP W POSITIONER

SPECIFICATIONS

Bonomi North America series MEN500S and MEN500N packages, include cast iron, epoxy coated, wafer style, resilient EPDM seat butterfly valves in sizes 11/2"-12" are NSF/ANSI61/372 certified.

This series shall offer a dual stem design and ISO 5211/DIN3337 direct mounting for high cycle automation capabilities.

In addition, the MEN500S-EN500N series features a phenolic-backed cartridge seat design which offers a 250CWP maximum pressure rating, dead-end service to 100 PSI, and conforms to ANSI B16.1 and ANSI B16.5

The MEN500 series also includes a rugged aluminum polyester powder coated metal housing NEMA 4 electric actuator, with standard features such as 2 extra limit switches, heater and thermostat, torque limiter, dual voltages, bubble type position indicator and a 75% duty cycle motor.

ACTUATOR FEATURES

- Dual Motors
- 24V AC/DC and 100-240V AC
- ISO 5211 dual patterns
- 75% Duty Cycle
- High-Strength, Die Cast Aluminum Powder Coated Housing
- Temperature Range -4°F to 131°F
- NEMA 4 Housing
- Two Auxiliary Switches Standard
- Torque limiter standard
- 1/2" Conduit connections

VALVE FEATURES

- ISO 5211 Direct Mount/Square Stem
- Epoxy coated Ductile Iron Wafer body
- EPDM resilient seat (-30°F TO 250°F)
- 530N/530S - VITON seats (10°F TO 300°F)
- 540S - BUNA seats (10°F TO 250°F)
- API609 face to face flange
- Floating dual shaft disc design
- MSS SP 67 compliant
- No pins in disc prevent potential leak points
- NSF/ANSI 61, 372 approved

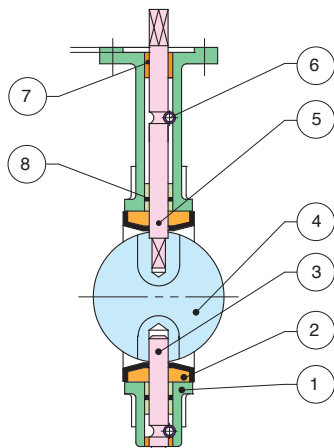

BILL OF MATERIALS

N POS	PART NAME	MODEL	MATERIAL	N PCS
1	BODY		CAST IRON	1
2	SEAT	N500N/N500S	EPDM (-30°F TO 250°F)	1
		530N/530S	VITON (10°F TO 300°F)	
		540S	BUNA (10°F TO 250°F)	
3	LOWER SHAFT		SS416	1
4	DISC 500N		CAST IRON / NYLON 11 COATED	1
	DISC 500S		STAINLESS STEEL	
5	UPPER SHAFT		SS416	1
6	LOCATING PIN		CARBON STEEL	1
7	BUSHING		P.T.F.E.	1
8	O-RING		EPDM	1
9	LEVER		EPOXY-COATED CARBON STEEL	1

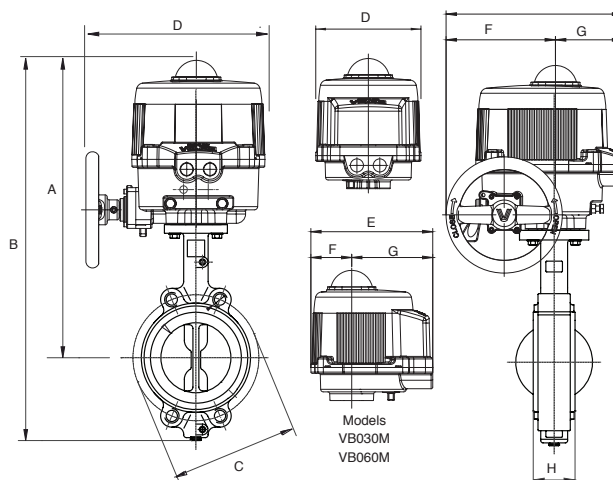

DIMENSIONS

Size	1-1/2"	2"	2-1/2"	3"	4"	5"	6"	8"	10"	12" **
A	13.54	14.17	14.72	14.96	16.53	18.02	18.58	19.96	21.22	25.77
B	16.51	17.32	18.22	18.70	21.02	23.02	24.05	26.85	29.21	35.30
C	4.74	4.74	5.49	6.00	7.50	8.50	9.50	11.75	14.25	17.00
D	6.34	6.34	6.34	6.34	6.93	10.63	10.63	10.83	10.83	15.50
E	7.36	7.36	7.36	7.36	7.76	10.47	10.47	10.98	10.98	11.57
F	2.48	2.48	2.48	2.48	2.48	6.50	6.50	7.24	7.24	7.24
G	4.88	4.88	4.88	4.88	5.28	3.98	3.98	3.74	3.74	4.33
H	1.61	1.65	1.76	1.78	2.05	2.14	2.20	2.34	2.58	3.03
Act.	VB060M	VB060M	VB060M	VB060M	VB060M	VB060M	VB190M	VB190M	VB350M	VB350M

* - available on MEN500S only

ON/OFF WIRING DIAGRAM

12V AC/DC, 24V AC/DC & 100-240VAC

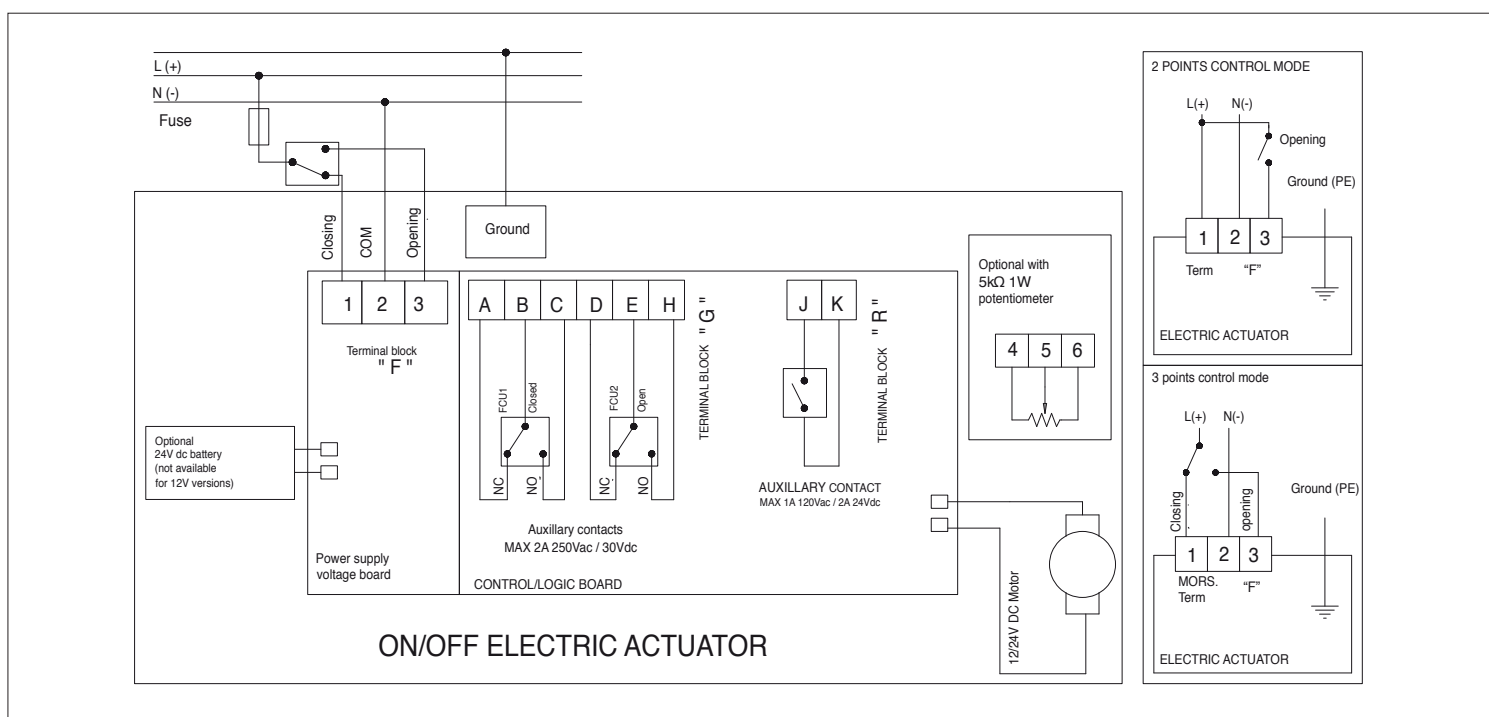

POSITIONER WIRING DIAGRAM

12V AC/DC, 24V AC/DC & 100-240VAC

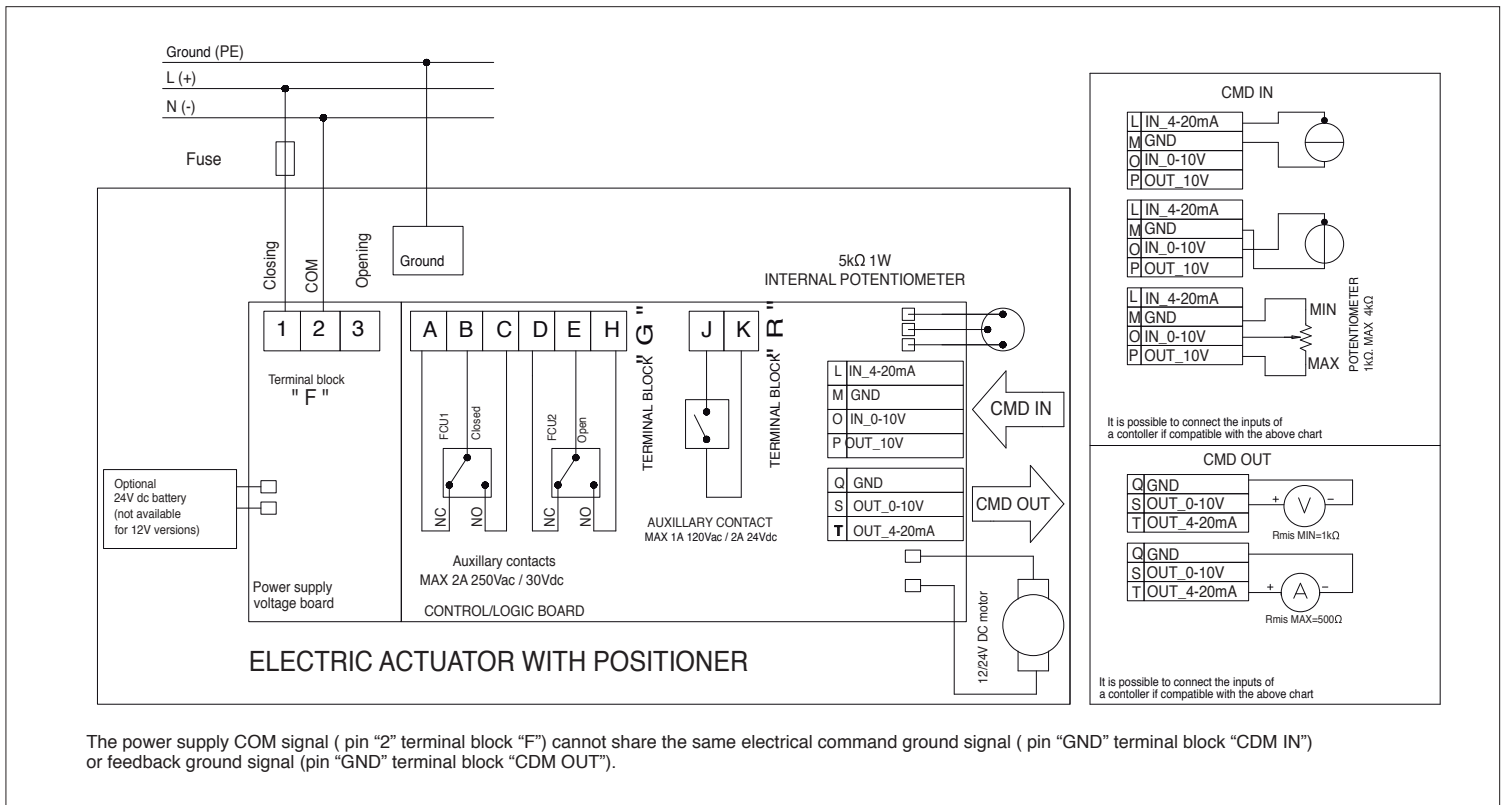

3-POSITION WIRING DIAGRAM - 3-WAY VALVES ONLY

12V AC/DC, 24V AC/DC & 100-240VAC

