

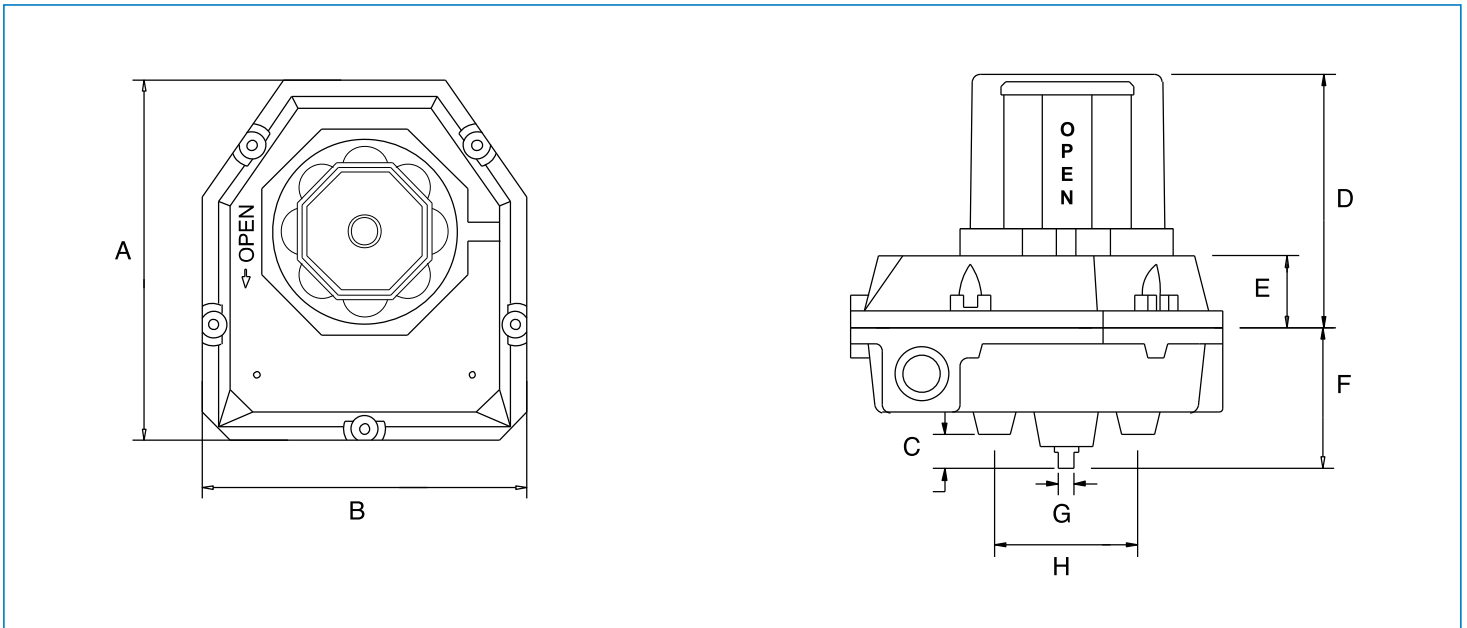

SERIES **MON-FMYB-5120** MECHANICAL LIMIT SWITCH



- Clear ektar copolyester cover.
- Die cast aluminum enclosure.
- Indicator shaft is secured to the housing unit.
- Flat cover version available.
- Environmentally sealed indicator.
- Minimum life of 1,000,000 cycles.
- Internal switches and terminal block
- Optional thermoplastic quick-mount bracket.
- Indicator is 100% adjustable.
- Nema 4, 4X.
- CSA approval.



ITEM TYPE	SPECIFICATIONS
Nema rating	4, 4X
Housing-cover	Aluminum
Indicator cover	Ektar copolyester
Seals	Buna-N
Fasteners	Stainless steel
Terminal points	8
Operating temperature	-40°F to 175°F
Agency approvals	CSA
Weight	4.25 lbs.

MODEL	DESCRIPTION	SUFFIX	US\$
MON-FMYB-5120	2 SPDT 15A mechanical	FM51	308.00
MON-BKT-NP120	SS bracket kit 52-100	-	55.00
MON-BKT-NP130	SS bracket kit 115-300	-	55.00